



**PROFESSIONAL 2-WHEEL TRACTOR
OPERATOR'S MANUAL**

FORM NO. 53210(6-92)

**PART NO. 47360, 47361, 47362, 47363,
47365, 47366, 47371, 47383,
49715**

**PRINTED IN USA
\$5.00**

NOTE

Read this manual carefully and learn to operate and service your tractor before using it.

To keep the warranty, the tractor must be maintained and operated as directed in this manual.

All references to "left-side", "right-side", "front" and "back" are given from the operator's position.

Use the serial numbers to ensure prompt and correct service when ordering parts, requesting service or making inquiries.

TRACTOR SERIAL NUMBER: _____

ENGINE SERIAL NUMBER: _____

ENGINE SPEC NUMBER: _____



Look for this symbol to point out important safety precautions. It means -- ATTENTION! BECOME ALERT! YOUR SAFETY IS INVOLVED.

CONTENTS

1. INSTRUCTIONS FOR SAFE OPERATION
2. CONTROLS
3. OPERATING INSTRUCTIONS
4. SERVICE INSTRUCTIONS
5. STORAGE
6. PROBLEM SOLVING
7. SPECIFICATIONS AND WIRING
8. SET-UP INSTRUCTIONS
9. WARRANTY

SECTION 1

INSTRUCTIONS FOR SAFE OPERATION

Improper use of this tractor can injure people and damage the equipment. People using or servicing this tractor must read and follow the instructions in this manual.

It is important to understand that this manual and any other Gravely instruction manuals do not cover every possible danger. It is impossible for Gravely to know of all possible dangers in operating and servicing the tractor and attachments.

The purchaser must give these instructions to the people operating and maintaining this tractor. These people must use eye and foot protection.

1.1 Preparation:

1. Read the tractor and attachment operator's manuals carefully.
2. Learn the location and function of all tractor and attachment controls.
3. Learn how to use the controls to stop the tractor and attachment.
4. Use caution with gasoline. Gasoline is very flammable. Keep it in a clean and tight container away from flames or hot items. Never put gasoline in the fuel tank while the engine is running or hot. Clean up spilled gasoline before starting engine.
5. Be certain that all shields, guards, and interlock switches are in the correct positions.
6. When hauling the tractor, connect the chassis and rear hitch to the transporting vehicle. Never connect from control levers, rods, or like items that could be damaged.
7. Check the operation of the operator presence controls before operating the mower.

1.2 Operation:

1. Wear hand, foot, head, ear and eye protection. Do not wear loose clothing.
2. Do not use the tractor in the dark without adequate lighting.
3. Keep the tractor in good condition. Maintain it as directed in this manual.
4. Replace all parts that become damaged or lost.
5. USE ONLY GRAVELY ACCESSORIES AND ATTACHMENTS OR ATTACHMENTS GRAVELY HAS APPROVED FOR USE WITH THIS TRACTOR.

6. Do not overspeed the engine. Do not override the governor.
7. Keep away from moving parts.
8. Keep people and animals away from the operating area.
9. Do not let people other than the operator ride on the sulky.
10. Use a slow speed and engage the direction control lever slowly when operating on slopes.
11. Look for and keep away from hazards.
12. Before starting the engine, put the direction control lever in the "NEUTRAL" position and the PTO control in the "OFF" position.
13. Look behind when operating in reverse.
14. After hitting an object with the tractor or attachment, stop the engine and check for damage. Repair any damage before continuing operation.
15. Operate the tractor only from the operator's position, just behind the handlebars. Never walk between the handlebars.
16. Travel across, not up and down slopes.
17. Never permit children to operate the tractor.
18. Before leaving the tractor, move the PTO control to "OFF" and turn the ignition switch to "OFF". When engine stops, lock the brake or put in gear and engage the direction control lever, and remove the ignition key.
19. If there is a sudden change in the sound or vibration of the tractor or attachments, stop the engine and check for damage or failure before continuing operation.
20. Never run the engine indoors except to move it outside. Exhaust fumes are dangerous.
21. Go slow on slick surfaces.
22. Follow traffic laws when operating on or near a road.
23. Before making adjustments or servicing, move the PTO to "OFF", turn the ignition switch to "OFF", and wait until all moving parts completely stop.

SECTION 2

CONTROLS

2.1 Direction Control Lever:

The direction control lever controls the movement of the tractor. Push the control forward to go forward. Pull the control back to move the tractor backwards. See Figure 1.

2.2 Gear Shift Lever:

The gear shift lever has two operating positions. The forward ("HIGH") position is the fast gear. The rearward ("LOW") position is the slow gear. See Figure 1.

The gear shift lever also controls the PTO speed. The forward ("HIGH") position is the fast PTO speed. The rearward ("LOW") position is the slow PTO speed.

NOTE: The gear shift lever must be in the "HIGH" or "LOW" position to properly transmit power to the PTO or wheels.

2.3 Range Shift Handle (2-Speed Axle Tractors):

The range shift handle (Figure 1) has two operating positions. Pull the handle to the rearward ("HIGH") position for the fast speed. Push the handle to the forward ("LOW") position for the slow speed.

Rocking the tractor back and forth by moving the direction control lever back and forth while moving the range shift handle will assist in the aligning the clutch teeth for engagement of the two-speed axle.

⚠ WARNING: Never move the handle while on a slope or while the tractor is moving. Move the handle only when the tractor is on level ground and stopped (except for rocking to engage the clutch as described above).

2.4 Throttle Lever:

The throttle lever (Figure 1) is used to control the engine speed. To increase the engine speed, move the lever up to the "FAST" position. To decrease the engine speed, move the lever down to the "SLOW" position.

2.5 Choke Control:

The choke control is used to choke a cold engine for starting. The choke control is located on the instrument panel (Figure 1). On 8 HP tractors, push the choke control up to the "ON" position to choke the engine. On all other tractors, pull the choke out to the "ON" position to choke the engine. When the engine is warm, move the control to the "OFF" position.

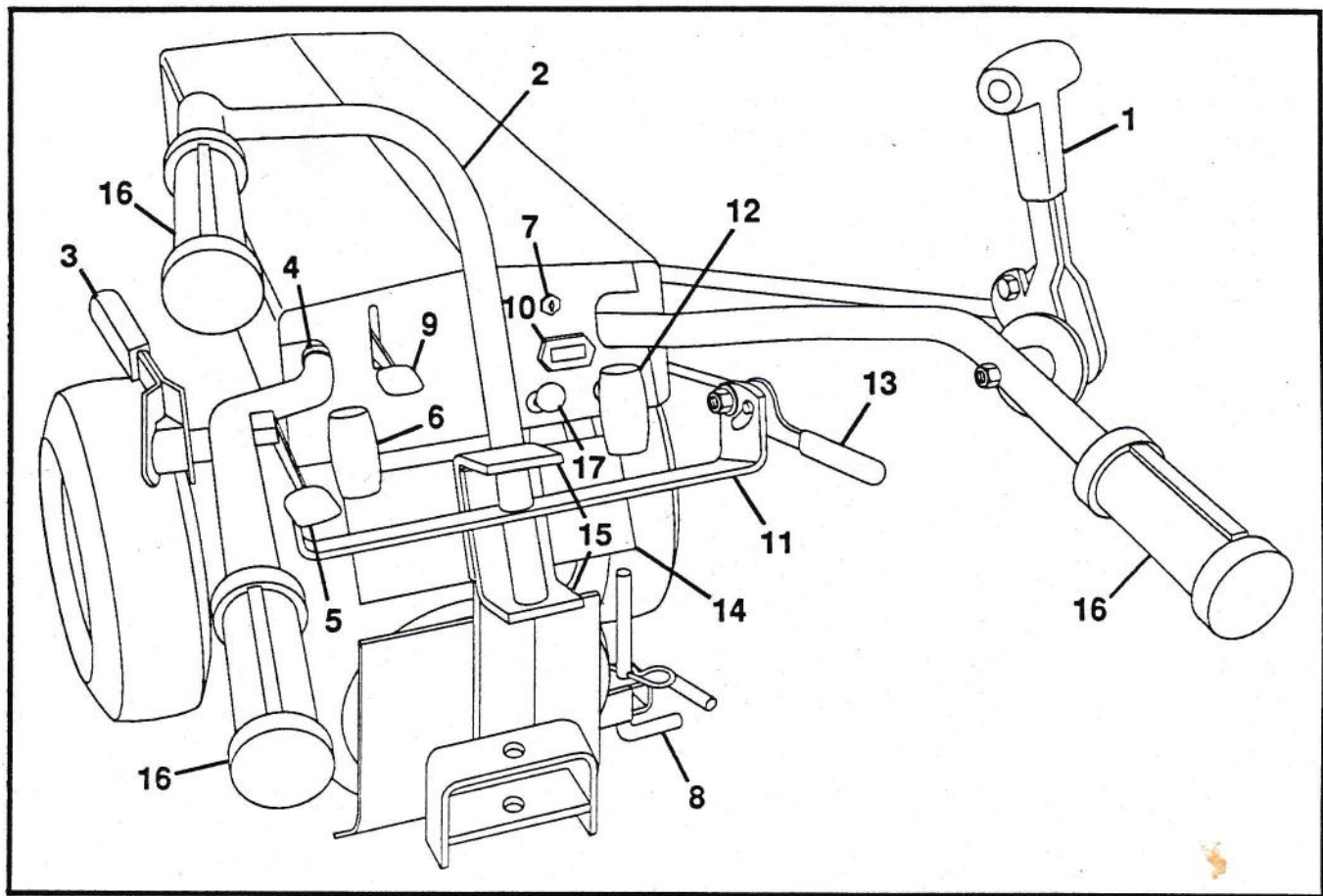

- | | |
|----------------------------------|-------------------------------------|
| 1 - Direction Control Lever | 10 - Hourmeter |
| 2 - Brake Handlebar | 11 - Brake Handle Cross Bar |
| 3 - Gear Shift Lever | 12 - Range Shift Handle |
| 4 - Conduit Clip | Differential Lock Control |
| 5 - Throttle Lever(8 HP) | (Differential Lock Tractors) |
| 6 - PTO Control | 13 - Parking Brake Handle |
| 7 - Ignition Switch | 14 - Instruction Plate |
| 8 - Kick Stand | 15 - Brake Handle Bracket |
| 9 - Choke Control(8 HP) | 16 - Operator Presence Control |
| Throttle Lever(10, 12 and 16 HP) | 17 - Choke Control(10,12 and 16 HP) |

FIGURE 1

2.6 PTO Control:

The PTO control(Figure 1) is used to connect or disconnect the engine power to an attachment. The forward position is "OFF"; the rearward position is "ON".

2.7 Ignition Switch:

The ignition switch is used to start(electric start models) and stop the engine(Figure 1).

2.8 Hourmeter:

The hourmeter(on some models) shows total time which the ignition switch has been in the "ON" position(Figure 1).

2.9 Fuse:

Electric start models have a fuse to protect the electrical system.

2.10 Kick Stand:

The kick stand is used to hold the tractor level when there is no attachment on the tractor. The kick stand must be in the raised position when moving the tractor. See Figure 1.

2.11 Brake Handlebar:

On tractors with steering brakes, the brake handlebar is used to steer the tractor. Swing the brake handlebar clockwise for a right turn or counterclockwise for a left turn(Figure 1).

2.12 Parking Brake:

The parking brake(Figure 1) is used to hold the tractor in position when not in use.

2.13 Operator Presence Control:

One of the operator presence control levers must be depressed so the power take off(PTO) or direction control lever can be operated.



CAUTION: The operator presence control is to protect the operator from the moving parts of the attachment and the powered moving of the equipment. Operate the equipment only when the operator presence control is in working condition.

2.14 Differential Lock:

The differential lock control is located on the lower right side of the instrument panel. To lock the differential, stop the tractor on level ground. Push the control forward. It may be necessary to rock the tractor back and forth with the direction control lever while pushing the differential lock control to engage the lock.

To unlock the differential, stop the tractor on level ground and pull the differential lock control back.

SECTION 3

OPERATING INSTRUCTIONS

NOTE: Read the tractor and attachment(s) manuals before operating the equipment. Operate the tractor only from the operator's position, just behind the handlebars. Service the tractor and attachment before operating.

3.1 Starting a Manual Start Engine:

1. Move the direction control lever to the "NEUTRAL" position.
2. Move the PTO control to the "OFF" position and the gear shift lever to the "NEUTRAL" position.
3. Put the key in the ignition switch and turn it to the "ON" position.
4. Move the throttle midway between the "SLOW" and "FAST" positions.
5. If the engine is cold, move the choke control to the "ON" position.
6. Pull the starter handle out until compression is felt in the engine. Then pull with one swift continuous motion. Hold the starter handle to allow a slow rewind of the rope.
7. After the engine starts and is warm, move the choke control (if used to start the engine) to the "OFF" position.
8. If the engine does not start after six pulls of the starter, see Section 6.

3.2 Starting an Electric Start Engine:

1. Move the direction control lever to the "NEUTRAL" position.
2. Move the PTO control to the "OFF" position and the gear shift lever to the "NEUTRAL" position.
3. Move the throttle lever midway between the "SLOW" and "FAST" positions.
4. If the engine is cold, move the choke control to the "ON" position.
5. Put the key in the ignition switch. Turn the key to the "START" position. When the engine starts, release the key.

NOTE: Do not operate the starter for more than 15 seconds. Allow 45 seconds for cooling before operating the starter again.

6. After the engine starts and is warm, move the choke control (if used to start the engine) to the "OFF" position.
7. If the engine does not start after six tries, see Section 6.

3.3 Stopping the Engine:

1. Move the direction control lever to the "NEUTRAL" position.
2. Move the throttle control to the "SLOW" position.
3. Move the HI/LO to the "NEUTRAL" position and the PTO control to the "OFF" position.
4. Turn the ignition key to the "OFF" position. Remove the ignition key before leaving the tractor.

3.4 Operating the Transmission:

1. Learn to operate the tractor in an open area while using a slow gear and slow engine speed.
2. Start the engine.
3. Move the gear shift lever to the "HIGH" or "LOW" position.
4. Move the range shift handle (if the tractor has a two-speed axle) to the "HIGH" or "LOW" position.
5. Move the throttle lever above the "SLOW" position (fast enough so that the engine will not stall).
6. Depress an operator presence handle (probably left).

NOTE: One of the operator presence control levers must be held down at all times whenever the transmission is in gear and/or the PTO lever is in the "ON" position.

7. To go forward, move the direction control lever forward until the lever stays in the forward position. If the lever is not in the full forward position, the clutch will slip and cause premature clutch wear.
8. Move the direction control lever to the rear to move backwards. The lever will not stay in the rear drive position. The lever must be held in the rear drive position.
9. To stop the tractor, put the direction control lever in the "NEUTRAL" position. You may now release the operator presence handle (only if the PTO is off).
10. Use slow gears when operating the tractor on rough ground, slopes, small areas, near buildings or other obstacles.

11. Use a slow gear and a fast engine speed when operating a snowblower, rotary cultivator, or a mower in heavy grass.
12. Walk behind, never between the handlebars.

3.5 Using the PTO:

1. Start the engine.
2. After the engine is warm, move the throttle lever just above the "SLOW" position.
3. Move the gear shift lever to the "NEUTRAL" position. Depress an operator presence handle(probably the right one).
4. Pull the PTO control back to the "ON" position with one continuous, fast pull.
5. Move the throttle lever to the "FAST" position.
6. Move the gear shift lever to the "HIGH" or "LOW" position.

NOTE: The gear shift lever must be in either the "HIGH" or "LOW" position to properly power the attachment.

7. Operate the direction control lever for desired travel.
8. To stop the power to the attachment, stop the tractor with the direction control lever, move the throttle lever to the "SLOW" position, move the gear shift to the "NEUTRAL" position and push the PTO control in (forward) to the "OFF" position. You may now release the operator presence handle.
9. When powering an attachment, move the throttle lever to the "FAST" position and control ground speed by selecting gear positions.

3.6 Using the Steering Brakes (on some models):

1. The steering brakes are used when the tractor is being driven forward.
2. To make a right turn, swing the brake handlebar clockwise.
3. To make a left turn, swing the brake handlebar counterclockwise.

 **CAUTION:** Use only the tractor handlebars to steer when driving in reverse.

4. To use the parking brake, pull up on the brake handle until the brake rod is at the top of the slot.

SECTION 4

SERVICE INSTRUCTIONS

Chart 1 shows the recommended service schedule that should be performed on a regular basis. See the engine manual for maintenance instructions. Use Chart 2 to record the actual hours on the hourmeter and the date at which each service item is performed.

MAINTENANCE SCHEDULE					
SERVICE PERFORMED	TIME INTERVALS BETWEEN SERVICE				
	DAILY	25 HR.	50 HR.	100 HR.	200 HR.
Check the Engine Oil (Section 4.2)	X				
Check the Engine Cooling System (Section 4.2)		X			
Check the Air Cleaner (Section 4.2)	X				
Lubricate all Pivot Points (Section 4.3)		X			
Check the Battery Fluid (Section 4.4)					X
Check the Battery (Section 4.4)					X
Check the Fasteners (Section 4.5)		X			
Adjust the Fwd-Rev Clutch (Section 4.6)		X			
Adjust the Gear Clutch (Section 4.7)		X			
Adjust the PTO Brake (Section 4.8)				X	
Adjust the Slip Clutch (Section 4.9)				X	
Check the Transmission Oil (Section 4.10)				X	
Lubricate the Ball of the Interlock Switches	X				
Check the Tire Pressure (Section 7)		X			

CHART 1

MAINTENANCE RECORD

SERVICE TO BE PERFORMED		TIME INTERVALS BETWEEN SERVICE	
	25 HRS.		
	ACTUAL HOURS		
	DATE		
	50 HRS.		
	ACTUAL HOURS		
	DATE		
	75 HRS.		
	ACTUAL HOURS		
	DATE		
	100 HRS.		
	ACTUAL HOURS		
	DATE		
	125 HRS.		
	ACTUAL HOURS		
	DATE		
	150 HRS.		
	ACTUAL HOURS		
	DATE		
	175 HRS.		
	ACTUAL HOURS		
	DATE		
	200 HRS.		
	ACTUAL HOURS		
	DATE		
	225 HRS.		
	ACTUAL HOURS		
	DATE		
	250 HRS.		
	ACTUAL HOURS		
	DATE		
	275 HRS.		
	ACTUAL HOURS		
	DATE		
	300 HRS.		
	ACTUAL HOURS		
	DATE		
	325 HRS.		
	ACTUAL HOURS		
	DATE		
	350 HRS.		
	ACTUAL HOURS		
	DATE		

CHART 2

MAINTENANCE RECORD

SERVICE TO BE PERFORMED	TIME INTERVALS BETWEEN SERVICE	
	ACTUAL HOURS	DATE
General Lubrication	375 HRS.	
Check the Fasteners	400 HRS.	
Check the Engine Cooling System	425 HRS.	
Check the Tire Pressure	450 HRS.	
Check the Transmission Oil	475 HRS.	
Check the Battery and Battery Fluid	500 HRS.	
	525 HRS.	
	550 HRS.	
	575 HRS.	
	600 HRS.	
	625 HRS.	
	650 HRS.	
	675 HRS.	
	700 HRS.	

CHART 2 (CONTINUED)

4.1 Filling the Fuel Tanks

WARNING: Use caution with fuel. Fuel is very flammable. Keep fuel in a clean and tight container. Keep fuel away from fire or heat. Never put fuel in the fuel tank while the engine is running or hot. Clean up any spilled fuel before starting the engine.

Add fuel to the fuel tanks as needed. See your engine manual for the correct type and grade of fuel.

1. Put the unit in an open area.
2. Stop the engine and lock the brake.
3. Clean the fuel cap and the area around the fuel cap to prevent dirt from entering the fuel tank. See Figure 2. Remove the cap from the fuel tank.
4. Fill the fuel tank. Be careful not to spill the fuel.
5. Install the cap on the fuel tank and tighten.
6. Clean up any spilled fuel before starting the engine.

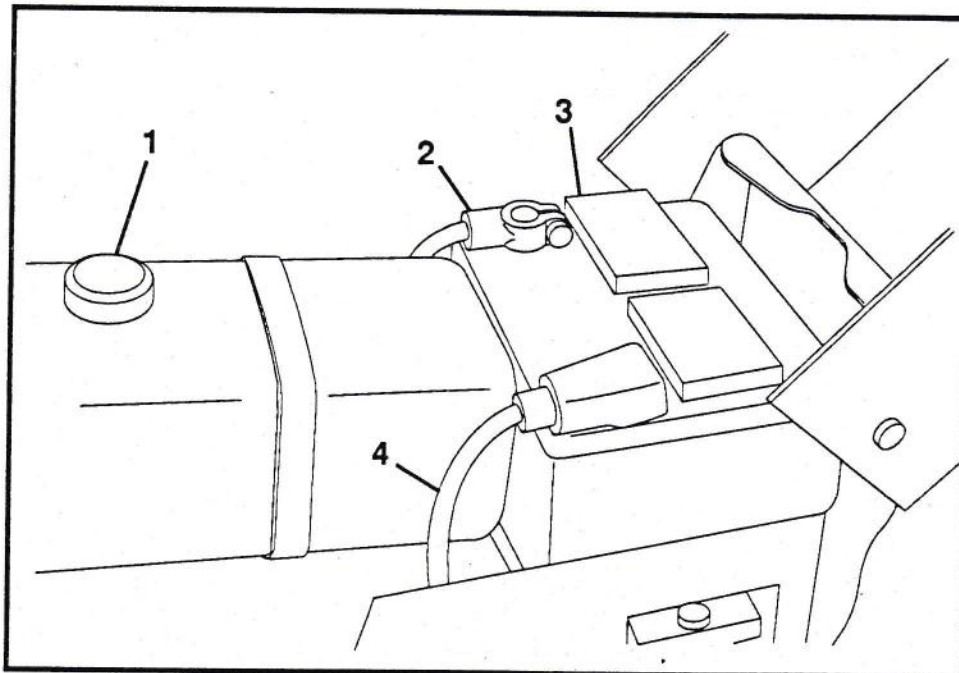

- 1 - Fuel Cap
- 2 - Negative Battery Cable
- 3 - Battery
- 4 - Positive Battery Cable

FIGURE 2

4.2 Engine Maintenance:

1. See the engine manual for maintenance instructions.
2. Check the air cleaner and engine oil daily. Check the cooling system every 25 hours.
3. Clean all of the grass and other material from the cooling fins and intake screen of the engine. If necessary, remove the engine shrouds to clean the engine.
4. See the engine manual for the type of oil, oil change, etc. Never operate the engine when the oil level is below the low mark on the dipstick.
5. See the engine manual for air cleaner maintenance instructions.

4.3 Control Linkage Lubrication:

Every 25 hours of operation put a drop of engine oil on the pivots of the throttle lever, the direction control lever, the gear shift lever, the PTO control, and range shift handle.

NOTE: There are no grease fittings on the tractor.

4.4 Battery Service (Electric Start Models):

1. The tractor is equipped with a low maintenance battery. Check the fluid level every 200 hours or at the end of the year. See Figure 2.
2. Keep the battery clean.
3. If acid is on the outside of the battery or the electrical connections are corroded, clean the outside of the battery with a water and baking soda solution.
4. Anytime the battery cables are to be disconnected, remove the negative (-) (ground) cable first. When replacing the battery cable connect the positive (+) cable first.
5. Anytime the battery cables are disconnected, the cable clamps and the battery post or connection should be cleaned until shiny. There are brushes made to clean the clamps and battery posts.

4.5 Fastener Check:

1. Check all fasteners after 25 hours of operation to make sure that they are tight.
2. Replace any fastener that is missing.
3. Tighten fasteners according to Chart 3.

BOLT TORQUE SPECIFICATIONS		
BOLT SIZE	FOOT POUNDS (ft.lbs.)	NEWTON METERS (N.m)
1/4"	7	9.5
5/16"	14	19
3/8"	25	34
7/16"	40	54
1/2"	60	82
9/16"	83	113
5/8"	120	163
3/4"	200	217

CHART 3

4.5 Forward-Reverse Clutch Adjustment:

1. After 25 hours of operation, check the adjustment of the forward-reverse clutch.

 **WARNING:** Stop the engine before adjusting the forward-reverse clutch.

2. The reverse clutch is adjusted correctly when the direction control lever stops 15 degrees past vertical to the rear. The lever should return to neutral position from reverse when adjusted correctly.
3. To adjust the reverse clutch, loosen the jam nuts on the end of the control extension rod in the fwd-rev control rod. Adjust the rear nut so that the direction control lever stops 15 degrees past vertical to the rear. Hold the rear nut and jam with the forward nut. See Figure 3.
4. The forward clutch is adjusted correctly when the direction control lever is in the full forward position and the large spring has a coil clearance of .010" (.254mm).
5. To adjust the forward clutch, put the direction control in the forward position. Loosen the rear set of jam nuts on the control extension rod in the fwd-rev control rod. Adjust the forward nut until the large spring coils are .010" (.254mm) apart. Hold the forward nut and jam with the rear nut.

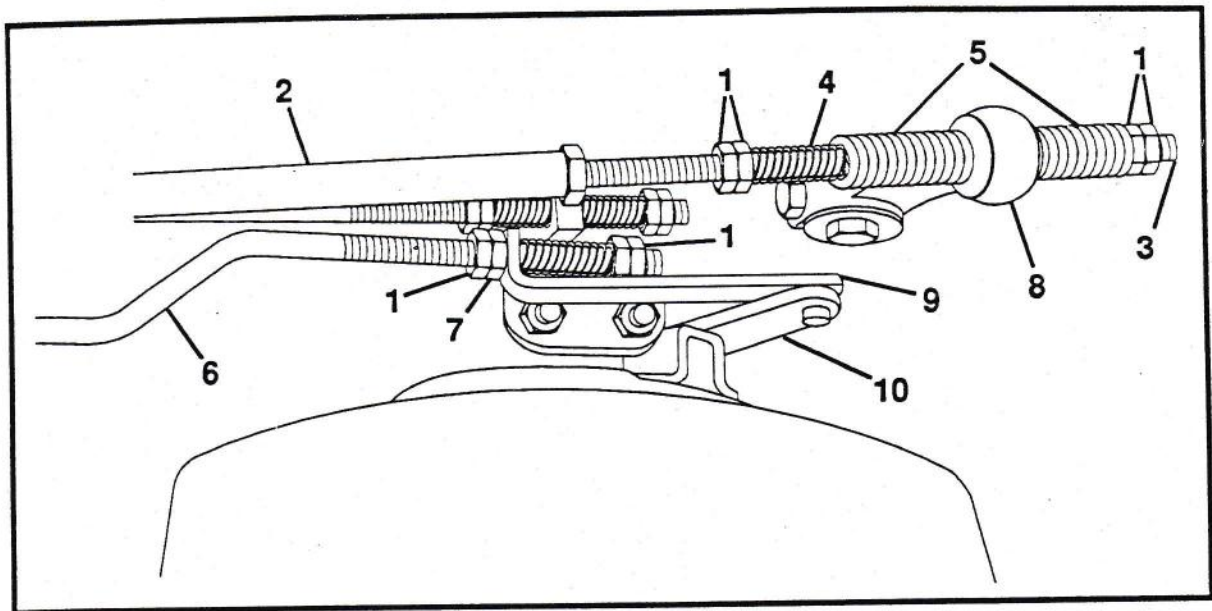

- | | |
|----------------------------|----------------------------|
| 1 - Jam Nut | 6 - Brake Rod Assembly |
| 2 - Fwd-Rev Control Rod | 7 - Adjusting Nut |
| 3 - Control Extension Rod | 8 - Fwd-Rev Lever Assembly |
| 4 - Fwd-Rev Neutral Spring | 9 - Adjustment Bracket |
| 5 - Large Spring | 10 - Cam Lever Arm |

FIGURE 3

4.6 Gear Clutch Adjustment:

1. After every 25 hours of operation, check the adjustment of the gear clutch.

⚠ WARNING: Stop the engine before adjusting the gear clutch.

2. The clutch is adjusted correctly when the gear shift lever is in the "HIGH" or "LOW" position and the spring coils are .010" (.254mm) apart.
3. To adjust the "HIGH" clutch, loosen and separate the jam nuts on the rear of the control extension rod in the Hi-Lo control rod. Put the gear shift lever in the "HIGH" position. Adjust the nut (front) near the spring until the spring coils are .010" (.254mm) apart. Move the gear shift lever to the "NEUTRAL" position. Hold the nut adjusted to the spring and jam with the other(rear) nut. See Figure 4.
4. To adjust the "LOW" clutch, loosen and separate the jam nuts on the end of the control extension rod in the Hi-Lo control rod. Put the gear shift lever in the "LOW" position. Adjust the nut(rear) near the spring until the spring coils are .010"(.254mm) apart. Move the gear shift lever to the "NEUTRAL" position. Hold the nut adjusted to the spring and jam with the other (front) nut.

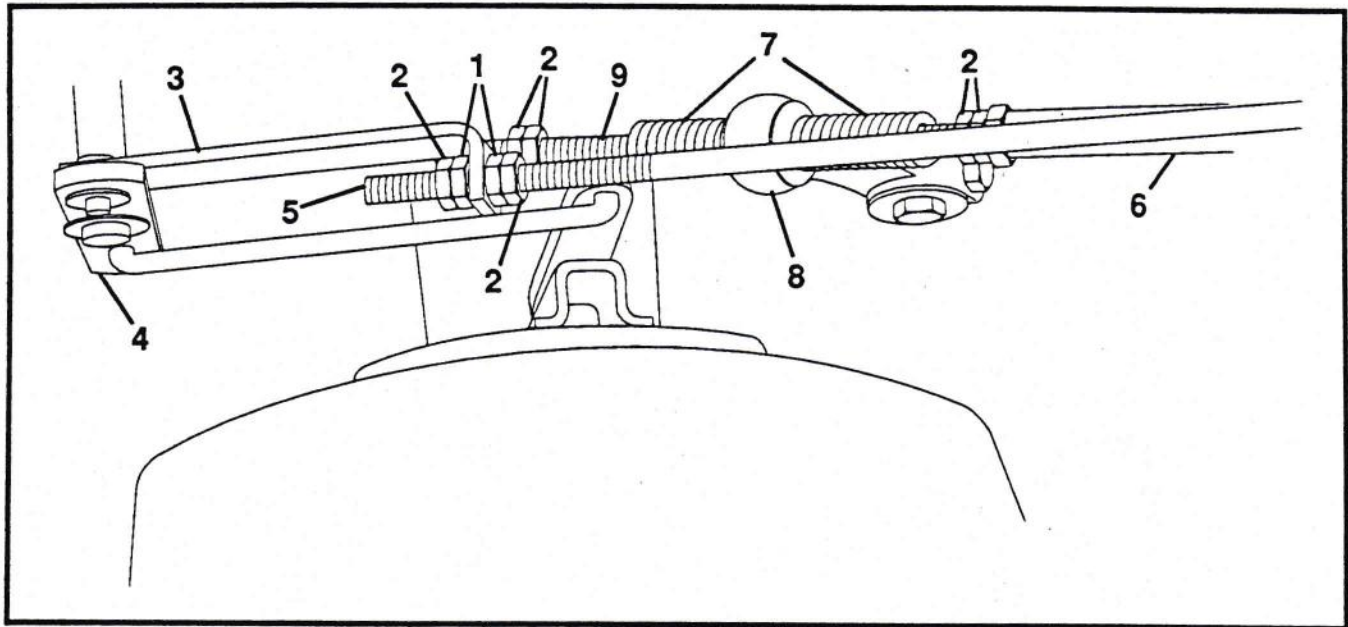

- | | |
|------------------------|---------------------------|
| 1 - Adjusting Nut | 6 - Hi-Lo Control Rod |
| 2 - Jam Nut | 7 - Large Spring |
| 3 - Adjustment Bracket | 8 - Hi-Lo Lever Assembly |
| 4 - Pivot Plate | 9 - Control Extension Rod |
| 5 - Brake Rod Assembly | |

FIGURE 4

4.7 PTO Brake Adjustment:

1. Adjust the PTO brake after every 100 hours of operation.

⚠ WARNING: Stop the engine before adjusting the PTO brake.

2. Remove the attachment and lower the rear of the tractor to the ground.
3. Carefully clean the front of the transmission.
4. Remove the quick hitch studs from the transmission and remove the quick hitch casting and PTO brake assembly. See Figure 5.

NOTE: The attachment gasket must be replaced if damaged.

5. Tighten all PTO brake bolts until the springs are solid. Back all bolts up 1/2 turn. See Figure 6.

NOTE: Do not tighten the bolts in a circular sequence, that is, by tightening the bolt next to one which was just tightened. The bolts should be tightened in a cross sequence, that is, by tightening one bolt, then tightening the bolt which is across from it on the plate. Continue tightening the bolts in this sequence until all the bolts are tightened.

6. Make sure the trunnion block is on the shipper shaft and held in place by the dog. The dog should rest on the spiral teeth of the clutch dog plate.
7. Install the gasket.
8. Align the splines on the quick hitch shaft with those in the dog. Slide the quick hitch casting and PTO brake assembly back into the place on the front of the transmission.
9. Install the quick hitch studs and tighten.

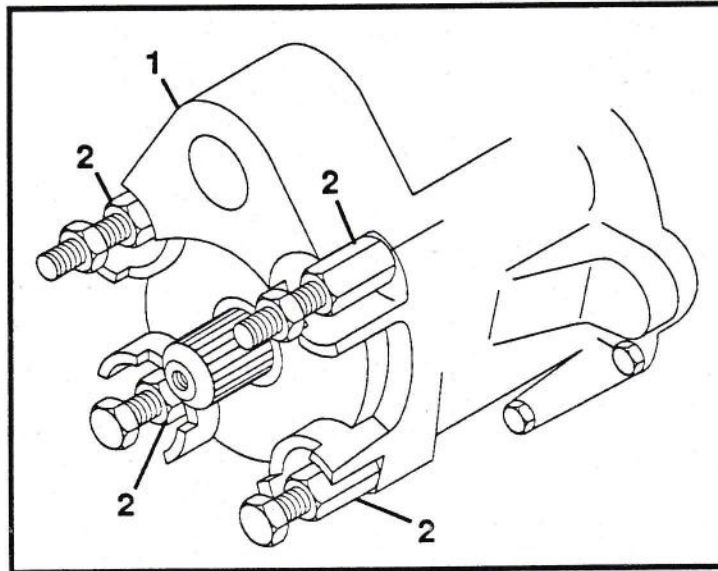

1 - Quick Hitch Adaptor

2 - Quick Hitch Stud

FIGURE 5

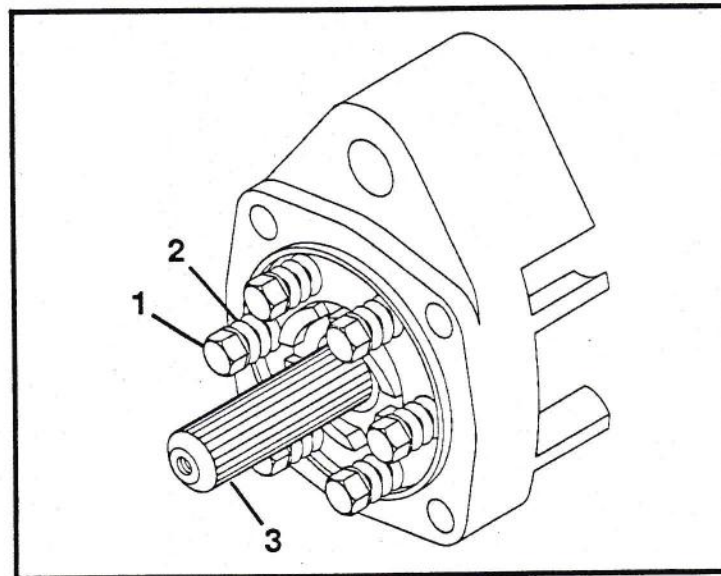

1 - PTO Brake Bolts

2 - Springs

3 - PTO Shaft

FIGURE 6

4.8 Slip Clutch Adjustment:

1. Adjust the slip clutch after every 100 hours of operation.

 **WARNING:** Stop the engine before adjusting the slip clutch.

2. Remove the attachment and lower the rear of the tractor to the ground.
3. Carefully clean the front of the transmission.
4. Remove the quick hitch studs from the transmission and remove the quick hitch casting and PTO brake assembly. See Figure 5.

NOTE: The attachment gasket must be replaced if damaged.

5. Remove the dog and trunnion block.
6. Disconnect the wiring harness from the PTO brake interlock switch and remove the shifter parts. (See the Tractor Illustrated Parts List, pages 1, 2, 3, 20 and 21.)
7. Slide the shipper shaft assembly through the top of the advance casting.
8. Slide the clutch assembly and pinion shaft out of the transmission. Remove the retaining ring and slide the clutch assembly off of the pinion shaft.
9. Turn all of the jam nuts counterclockwise to loosen. See Figure 7.
10. Tighten all of the adjusting bolts until the springs are solid. Then turn all of the bolts counterclockwise one-half turn.

NOTE: Do not tighten the bolts in a circular sequence, that is, by tightening the bolt next to one which was just tightened. The bolts should be tightened in a cross sequence, that is, by tightening one bolt, then tightening the bolt which is across from it on the plate. Continue tightening the bolts in this sequence until all the bolts are tightened.

11. Tighten the jam nuts against the back plate.
12. Slide the clutch assembly back onto the pinion shaft, install the retaining ring and slide the pinion shaft completely into the transmission.
13. Install the shipper shaft and other parts that were removed in Step 6.
14. Make sure the trunnion block is on the shipper shaft and held in place by the dog. The dog should rest on the spiral teeth of the clutch dog plate.
15. Install the gasket.

16. Align the splines on the quick hitch shaft with those in the dog. Slide the quick hitch casting and PTO brake assembly back into place on the front of the transmission.
17. Install the quick hitch studs and tighten.

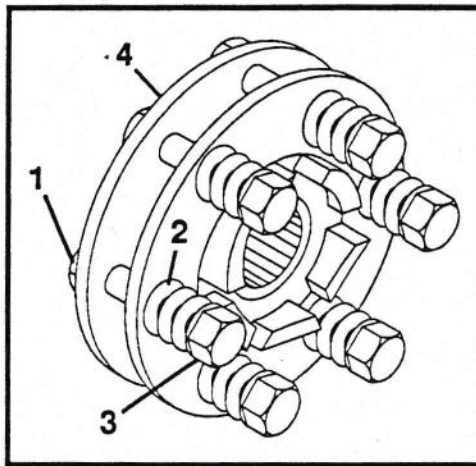

- 1 - Jam Nut
 - 2 - Spring
 - 3 - Adjusting Bolt
 - 4 - Back Plate
- FIGURE 7

4.9 Transmission Lubrication:

1. After every 100 hours of operation, check the level of the lubricant in the transmission.
2. Never operate the tractor when the transmission oil level is below the "LOW" mark on the dipstick.
3. Stop the engine and raise the hood. Make sure that the tractor is level.
4. Clean the dipstick tube and the dipstick. See Figure 8.
5. Remove the dipstick, wipe it with a clean cloth or towel and put it back in the tube.
6. Pull the dipstick out again and look at the oil.
7. If the oil level is below the low mark on the dipstick, clean the area around the filler plug and remove the filler plug.
8. Add new clean lubricant until the dipstick indicates that the oil level is correct. See Section 7.
9. Install the filler plug and the dipstick.

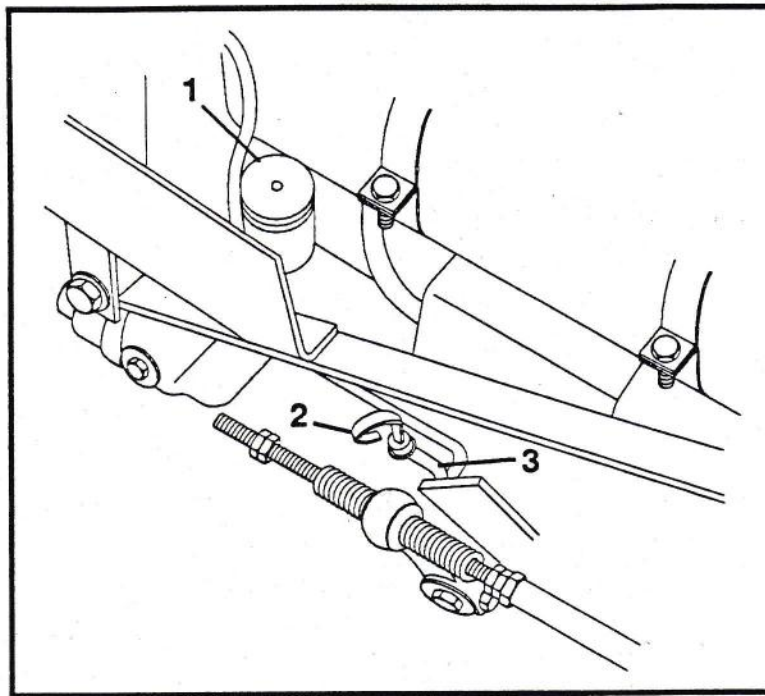

1 - Oil Filler Plug
 2 - Dipstick
 3 - Dipstick Tube
 FIGURE 8

4.10 Steering Brake Adjustment (on some models):

1. Park the tractor in a level area.
2. Put the parking brake handle in the "OFF" (down) position.
3. Loosen the jam nuts on the right and left brake rod assemblies. See Figures 3 and 4.
4. Turn the adjusting nuts until the brake handle cross bar is parallel with the instrument panel. See Figure 1.
5. Move the brake handlebar all the way to the right and measure the distance from the right end edge of the brake handle cross bar to the right side of the instrument panel. Move the brake handlebar all the way to the left and make the same measurement on the right. Adjust the nuts until the difference between the two measurements is 1/2" to 3/4" (13 to 19 mm). Turn both adjusting nuts the same amount, clockwise to increase the measurement difference or counterclockwise to decrease the measurement difference.
6. Tighten the jam nuts.
7. Loosen the jam nuts below the compression spring on the right side of the tractor and adjust until one has the desired tension for the right brake.
8. Tighten the jam nuts.

SECTION 5

STORAGE

5.1 When the tractor will not be operated for two months or more:

1. Do the daily and 25-hour maintenance, but do not add gasoline.
2. Clean the tractor. Paint or oil bare metal surfaces to prevent rust.

NOTE: Do not use harsh or abrasive cleaners on any painted surface. Do not allow gasoline or oil to remain on any silk screened surface.

3. Refer to the engine manual and prepare the engine for storage.
4. Charge the battery initially and then every three weeks.

5.2 To put the tractor into service:

1. Refer to the engine service manual and prepare the engine for service.
2. Charge the battery.
3. Put fresh, clean gasoline in the fuel tank.

SECTION 6

PROBLEM SOLVING

OBSERVATION	POSSIBLE CAUSE
1. Starter will not operate when the ignition key is turned to the "S" position.	Fwd-Rev lever in "FORWARD" position PTO engaged Defective solenoid switch Blown fuse Discharged battery Loose battery cable(s) Defective starter Faulty interlock switch
2. Solenoid switch clicks but starter will not operate when the ignition is turned to the "S" position.	Discharged battery Defective starter Loose battery cable(s)
3. Engine starter operates but engine will not start when the ignition switch is turned to the "S" position.	Fuel tank empty Fuel shut-off valve at the fuel tank turned off Engine failure-See Engine Manual
4. Engine starts but runs roughly.	Restricted fuel cap vent Engine carburetor malfunction-see Engine Manual Engine choke in "ON" position Restricted air cleaner element Engine electrical system trouble - see Engine Manual
5. Engine stops when PTO or Fwd-Rev is engaged.	Operator presence handle not pressed Operator presence handle out of adjustment Faulty switch
6. The tractor will not move when the direction control lever is moved to "FORWARD" or "REVERSE" position.	Gear shift lever in "NEUTRAL" position Range shift handle in "NEUTRAL" position Fwd-Rev clutch needs adjustment
7. Attachment will not operate.	Attachment jammed or damaged. Gear shift lever in "NEUTRAL" position Attachment slip clutch needs adjustment or repair
8. Attachment operates slowly.	Attachment slip clutch needs adjustment or repair. Attachment damaged. Engine problems - See Engine Manual
9. The transmission will not go into "HIGH" range when range shift handle is moved to "HIGH" position.	Debris blocking the linkage Rust on the clutch sliding pin

SECTION 7

SPECIFICATIONS AND WIRING

7.1 Specifications:

Engine Fuel	See Engine Manual
Engine Oil	See Engine Manual
Fuel Tank Capacity	1.25 US Gallons (3.6 liters) Engine-Mounted Tank 2 US Gallons (7.6 liters) Frame-Mounted Tank
Transmission Oil Capacity	5 US Quarts (4.75 liters)
Transmission Oil Type	10W-30 Engine Oil
Tire Sizes Available	4.00-8 Diamond Tread 4.00-8 Ground Grip Tread 18x6.50-8 Turf Tread 18x8.50-8 Turf Tread 16x5Wx3 Semi-Pneumatic Ground Grip 19x5 Semi-Pneumatic Ground Grip
Tire Pressure	18 psi (124kN/m ²)
Weight Range	355 lbs. (161kg) to 476 lbs. (215.9kg)
Dimensions	58"Lx25"Wx36.5"H (1470mmx640mmx930mm)

Ground Speeds (at 3300 rpm engine speed):

(NOTE: Grounds speeds are faster with bigger tires.)

8 H.P., 2-speed with 4.00x8 tires

Fwd: 2.0 mph (3.2 kmph) to 2.5 mph (4.0 kmph)
Rev: 1.9 mph (3.1 kmph) to 2.4 mph (3.9 kmph)

8 H.P., 4-speed with 4.00x8 tires

Fwd: Lo range-1.3 mph (2.1 kmph); 1.7 mph (2.7 kmph)
Hi range-2.6 mph (4.2 kmph); 3.4 mph (5.5 kmph)
Rev: Lo range-1.2 mph (2.0 kmph); 1.6 mph (2.6 kmph)
Hi range-2.4 mph (3.9 kmph); 3.1 mph (5.0 kmph)

10, 12 and 16 H.P., 4 speed with 18x6.50-8 tires

Fwd: Lo range-1.4 mph (2.3 kmph); 1.8 mph (2.9 kmph)
Hi range-2.7 mph (4.4 kmph); 3.7 mph (6.0 kmph)
Rev: Lo range-1.3 mph (2.1 kmph); 1.7 mph (2.7 kmph)
Hi range-2.6 mph (4.2 kmph); 3.3 mph (5.3 kmph)

7.2 Wiring:

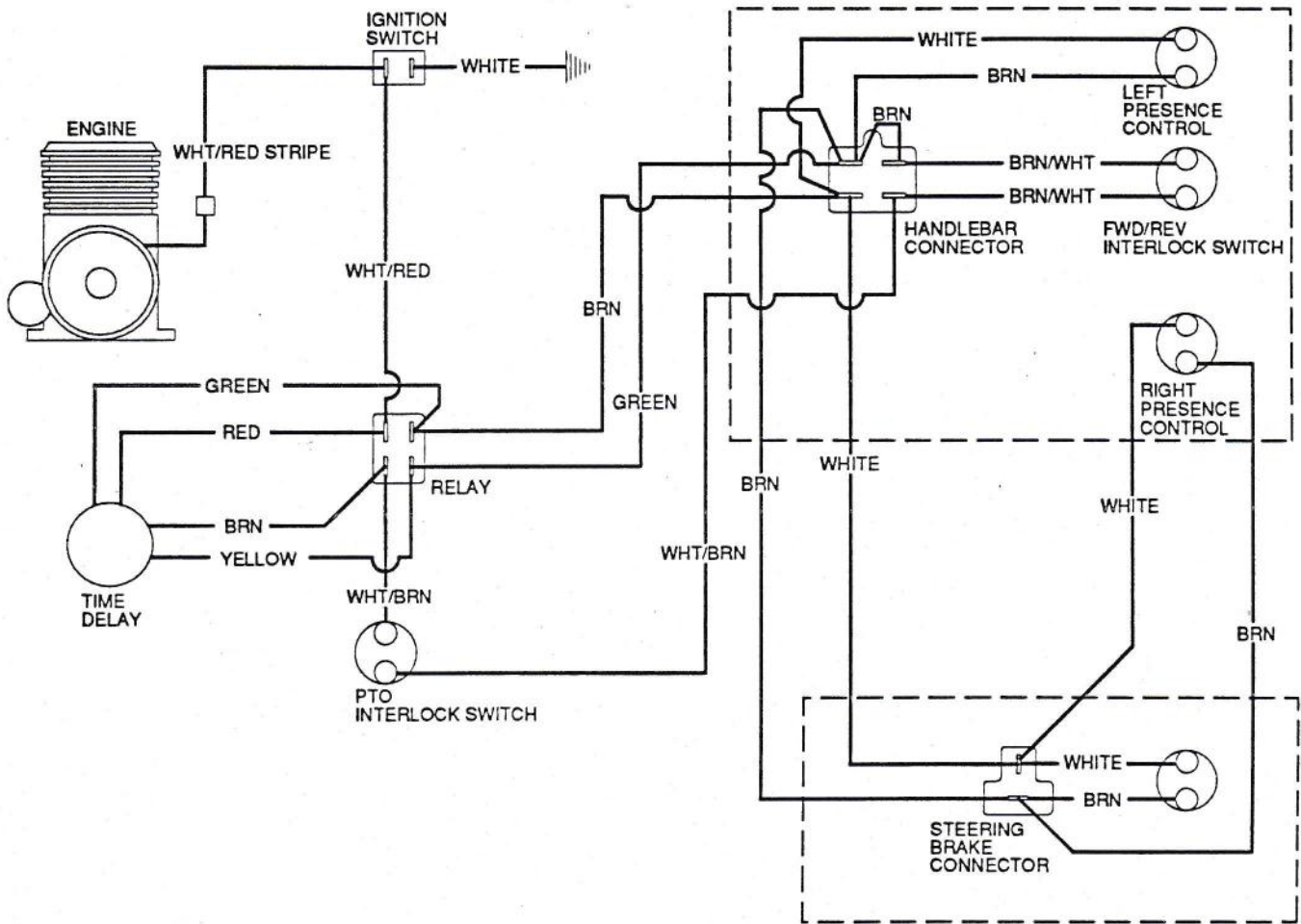

8 AND 12 H.P. MANUAL START

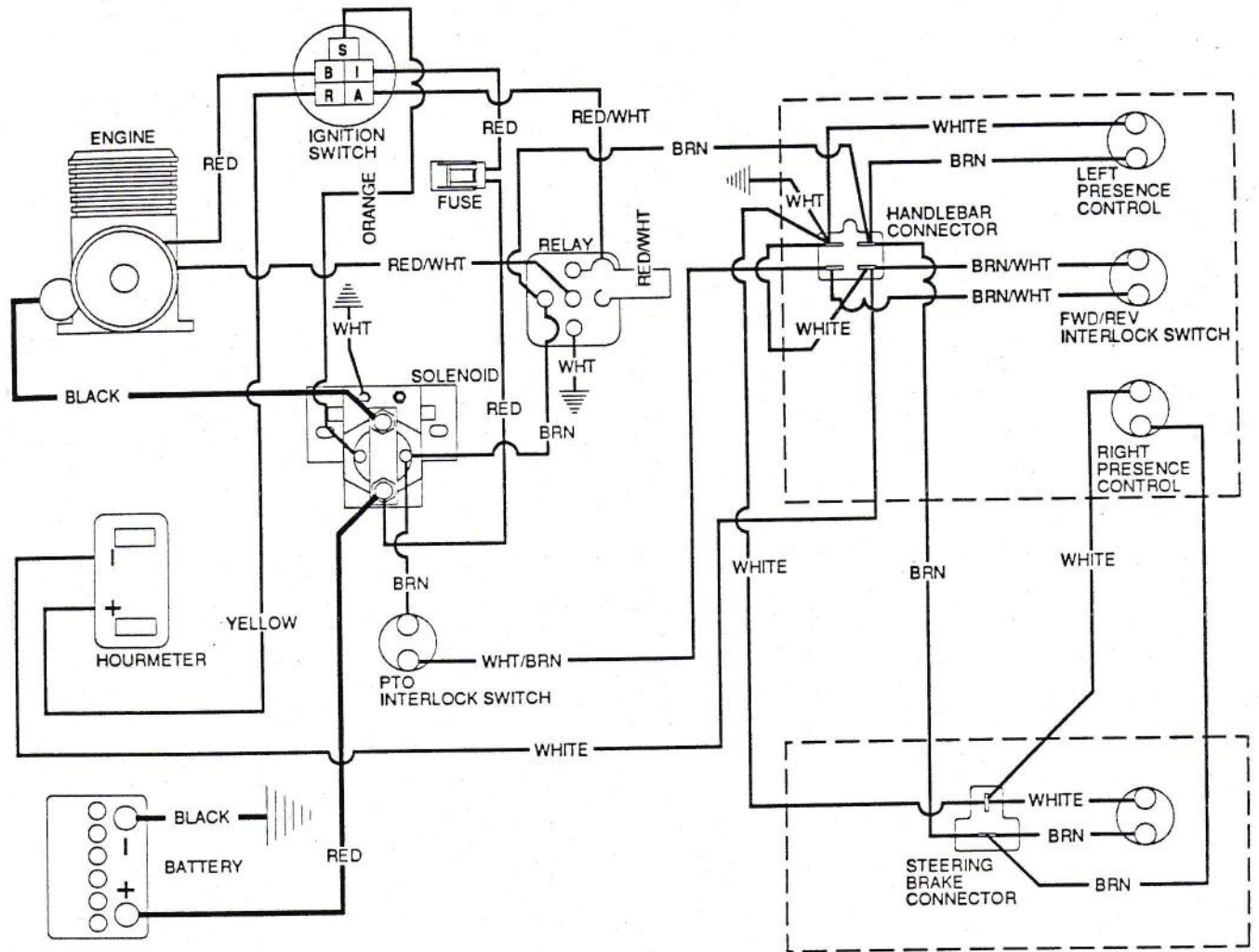

8 H.P. ELECTRIC START

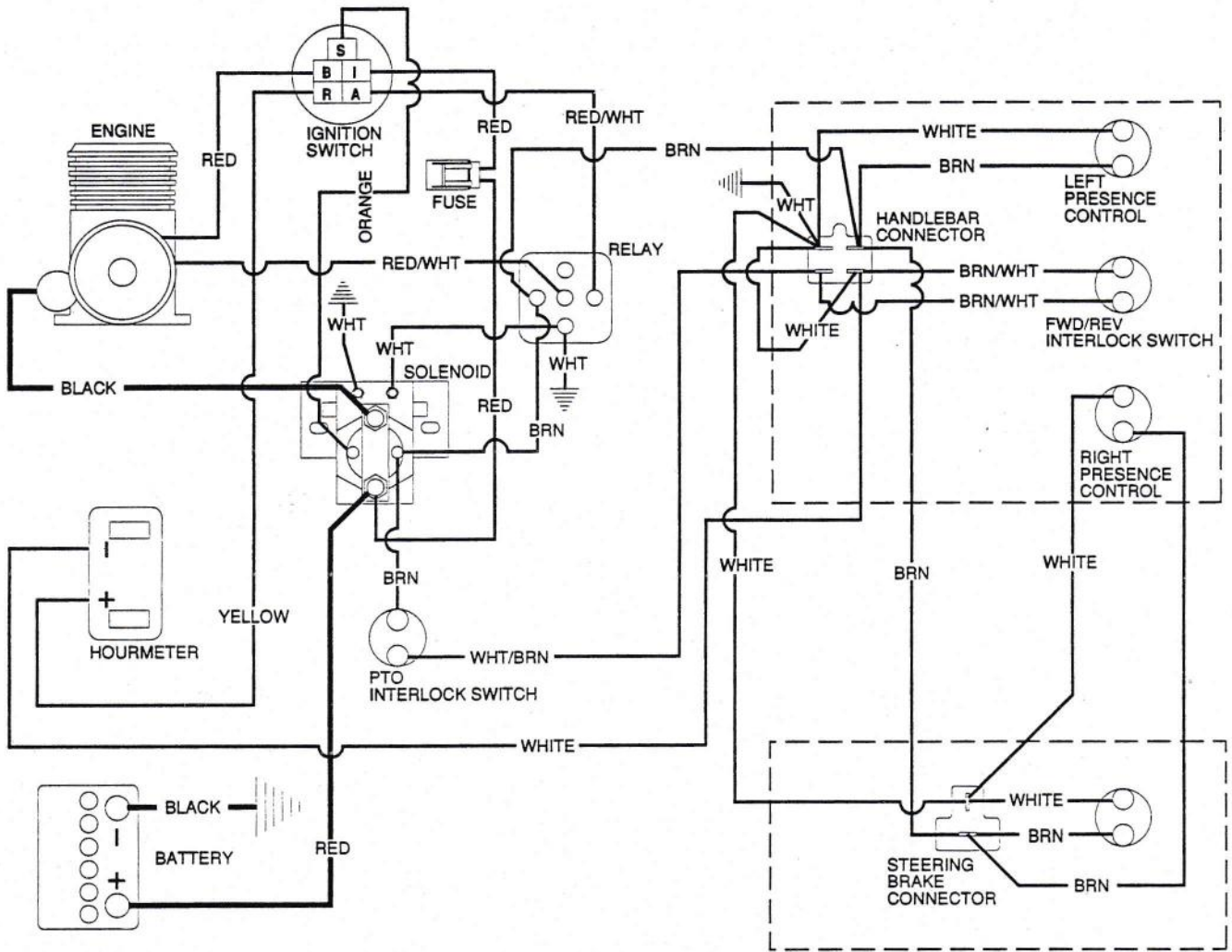

10 AND 12 H.P. ELECTRIC START

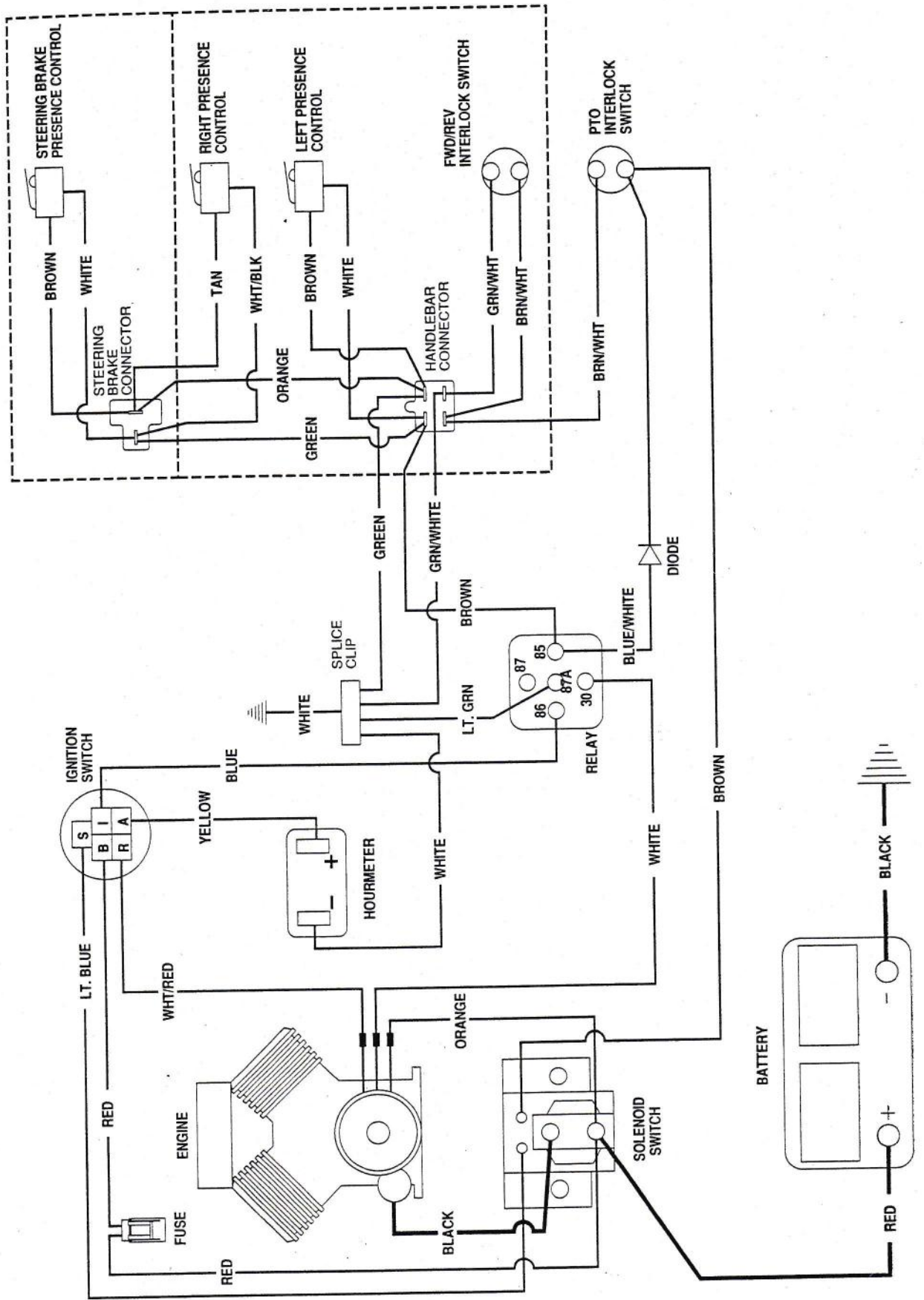

16 H.P. ELECTRIC START

SECTION 8

SET-UP INSTRUCTIONS

- 8.1 Remove the tractor and the handlebar from the shipping container.
- 8.2 On swiftamatic tractors, disconnect the cotter pin that holds the swiftamatic control lever to the shifter weldment. Disconnect the extension spring from the control lever and slide the control lever rearward until it stops against the instrument panel. See Figure 9.
- 8.3 Position the handlebar right side up. Move the left handle of the handlebar under the right side of the frame and the wiring harness. Proceed across the engine and out between the left side of the frame and the PTO control. Rotate the handlebar into the mounting position.
- 8.4 Retain the handlebar in position with four 3/8-16x1.25 Grade 8 bolts and lock nuts. The Grade 8 bolt has six marks on the head. See Figure 10.
- 8.5 Reassemble the swiftamatic control lever linkage and connect the wiring harness.
- 8.6 Mount the Hi-Lo gear control handle assembly and hand lever pivot to the left handle with a 1/2-13x3.50 bolt and 1/2-13 thin lock nut. See Figure 11 and the Illustrated Parts List.
- 8.7 On 8 H.P. tractors, mount the throttle control to the left handlebar with two 10-24x1.50 machine screws and two 10-24 lock nuts. Secure the throttle cable assembly to the handlebar with a conduit clip near the instrument panel.

NOTE: The 10, 12 and 16 HP model tractors have the throttle control assembled on the instrument panel. These tractors do not require Step 8.7.

- 8.8 On models with steering brakes, assemble as follows:
 1. Fasten the instruction plate and the brake handle brackets to the rear hitch with the 1/2-13x2 bolts and 1/2-13 lock nuts. (NOTE: On tractors equipped with a sound shield, the nuts are not needed. Replace the 1/2-13x1.25 bolts with 1/2-13x2 bolts. Use the 1/2 lock washers that were removed.)
 2. Left Side Installation: Slide the rear of the rod into the left inside end of the handlebar weldment. See the Steering Brake illustration in the Illustrated Parts List. Connect the other end to the pivot plate with a .375x.75 clevis pin, two .406x.812x.065 flat washers and a .09x.75 cotter pin. See Figure 4. See Section 4 for adjustment.

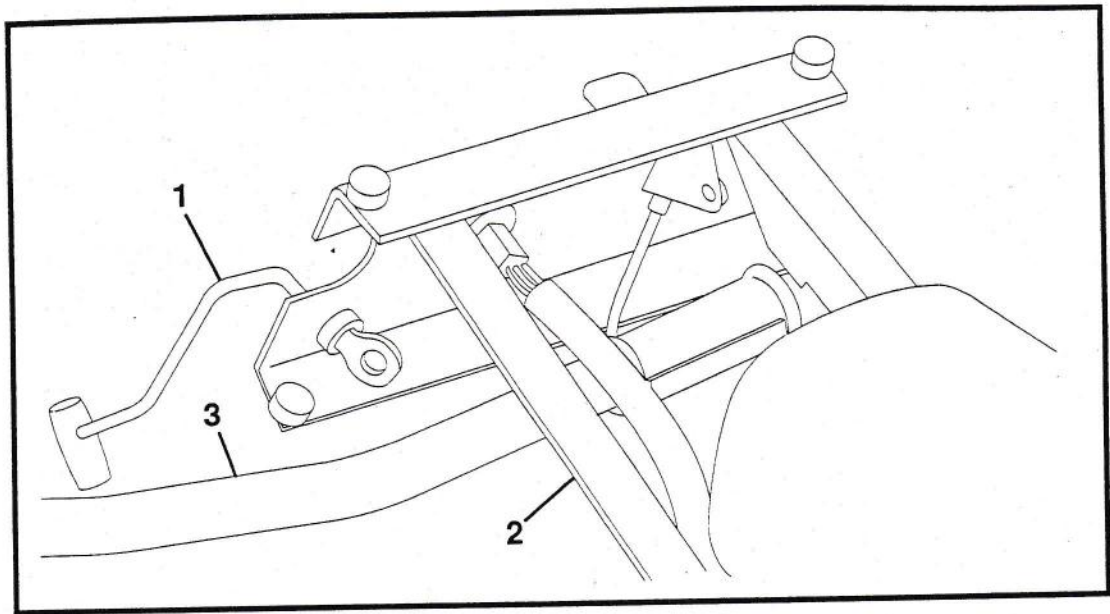

1 - Control Lever
2 - Frame
3 - Handlebar
FIGURE 9

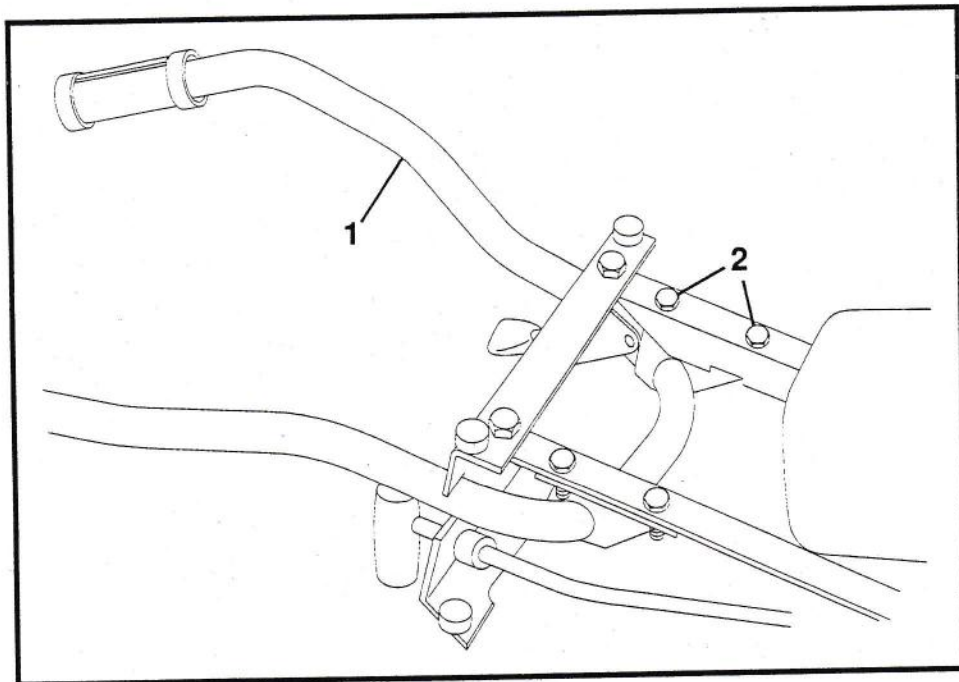

1 - Handlebar
2 - Grade 8 Bolt
FIGURE 10

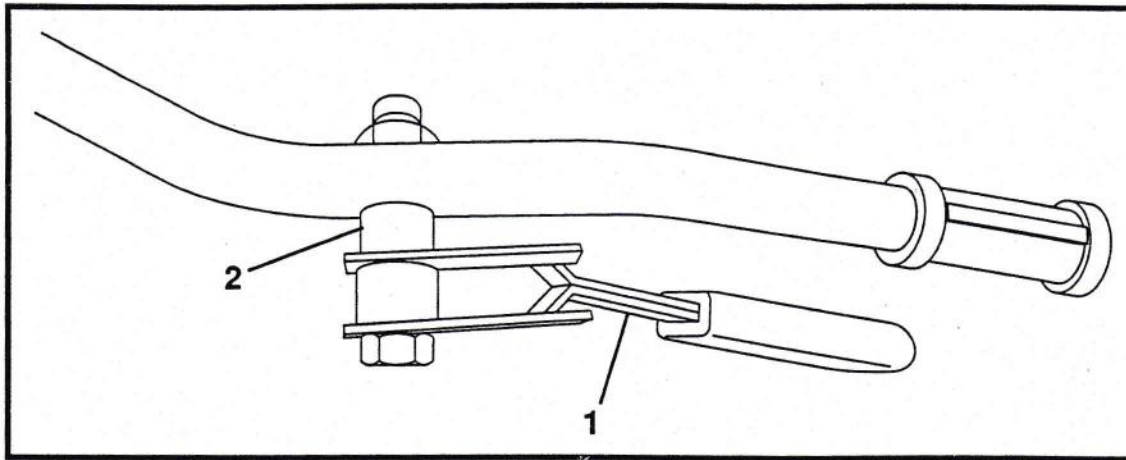

1 - Hi-Lo Control Handle Assembly
 2 - Hand Lever Pivot
 FIGURE 11

3. Right Side Installation: Slide the brake handle onto the brake rod and insert the rod into the slot of the brake handlebar weldment. Place the carriage bolt through the brake handle, and put two nylon washers on the bolt between the handle and the handlebar weldment. Push the bolt through the handlebar weldment and retain with another nylon washer, rubber washer, steel washer and lock nut. Connect the adjustment bracket to the cam lever arm with a clevis pin, two .406x.812x.065 flat washers and .09x.75 cotter pin. See Figure 3. See Section 4 for adjustment.
4. Connect the interlock plug to the wiring harness.
- 8.9 Connect the Fwd/Rev and Hi-Lo gear control rods to the tractor and their respective handles using bushing (41244), 1/4-20x1.5 bolts, .281x.625x.065 flat washers and 1/4-20 lock nuts. See the Gear Shift Control and Direction Control sections of the Illustrated Parts List.
- 8.10 On tractors not equipped with a maintenance-free battery, remove the battery and place on a bench or other place which is well ventilated and acid spill will not create damage. Fill the battery to the bottom of the fill tubes with 1.265 specific gravity electrolyte. Twenty minutes after filling with electrolyte, charge the battery at 6 to 8 amps for 20 minutes. Follow charger manufacturer's instructions for safe procedure. Wait 20 minutes after charging before replacing the battery vent caps and placing on chassis.
- 8.11 If the tractor is equipped with the part number 22507 wheel hubs, fasten the wheel assemblies to the wheel hubs using the six 3/8-16x.75 hex bolts. If the tractor is equipped with the part number 23267 rims, fasten the wheel assemblies to the rims using the eight 1/2-13x1.50 hex bolts and lock nuts.
- 8.12 Check to see that interlock systems operate correctly.
- 8.13 Service the tractor according to the instructions found in Section 4.

SECTION 9

LIMITED FIVE-YEAR WARRANTY

1. This Limited Five-Year Warranty is issued by Gravely International, Inc., only to the original purchaser. If Gravely equipment is leased by Gravely, this Warranty shall extend also to the original lessee as if such lessee were the original purchaser.
2. Gravely warrants that all new equipment manufactured by Gravely ("Gravely Products") shall be free of defects in material and workmanship for the term described in paragraph 4, below. Except as hereinafter provided, this Warranty does not cover any engine, tires or battery forming a part of the Gravely Product. Engine and tires are covered by and subject to separate warranties of the manufacturers thereof.
3. In the event that any Gravely Product warranted hereunder shall be defective or fail to conform with this Warranty, Gravely shall, subject to the provisions hereof, pay for, or provide labor and materials for, the repair or replacement of such defective Gravely Product.
4. This Warranty is for five years (60 months) from purchase date for Gravely Products used exclusively for personal, family or household purposes, and two years (24 months) for products used for other purposes (commercial use), excluding rental firms. Gravely products used for rental purposes will be warranted for 90 days. Repair of Gravely Products after the second year (24 months from date of purchase) shall be subject to a \$50.00 deductible for each repair. (After two years, Gravely agrees to repair or replace defective Gravely Products used exclusively for personal, family or household purposes only to the extent that the cost of such warranty covered repair or replacement exceeds \$50.00.)

Batteries are warranted by Gravely for a period of twelve (12) months only. If a battery shall fail within twelve (12) months of purchase, the replacement cost thereof shall be prorated over a twelve-month term based upon the number of months since purchase.
5. To obtain Warranty Service on a Gravely Product (including any battery or other component not manufactured by Gravely), use this procedure:
 - a. Notify the Gravely dealer from whom you purchased the equipment.
 - b. If you have moved and it is not convenient to notify the selling dealer, notify the nearest Gravely dealer. You should supply this dealer with a copy of the bill of sale as proof of the date of purchase.
 - c. Make arrangements to have the equipment delivered to the dealer (refer to paragraph 6 a., below).
 - d. If you have any questions concerning the Gravely Limited Warranty, they should be referred to:

Gravely International, Inc.
One Gravely Lane
Clemmons, NC 27012
Attn: Customer Service Department
 - e. Warranty Service on Gravely Products must be performed by an authorized Gravely dealer.
6. This Warranty does not cover the following:
 - a. Transportation to the Gravely dealership. (If the Gravely dealer provides transportation, he will charge for such service.)
 - b. Normal maintenance services and normal replacement of items such as spark plugs, belts, oil, oil filters, air filters, and mower, plow or cultivator blades, gauge wheels, skids and other wear items.
 - c. Any Gravely Product which has been altered or modified in any way.
 - d. Any repair or replacement occasioned by customer neglect or lack of proper maintenance. (The purchaser is responsible for making sure that Gravely Products are operated and serviced as directed in the applicable manual or service instruction. Incorrect use or maintenance will void this Warranty.)
 - e. Any repair occasioned by the use of any attachment not approved by Gravely. (The use of any such unapproved attachment will void this Warranty.)
7. GRAVELY MAKES NO OTHER EXPRESSED OR IMPLIED WARRANTIES, OR WARRANTIES AS TO THE MERCHANTABILITY OR FITNESS FOR A PARTICULAR PURPOSE. ALL WARRANTIES ARE LIMITED IN DURATION TO THE TERMS SET OUT IN PARAGRAPH 4, ABOVE. GRAVELY SHALL HAVE NO LIABILITY FOR INCIDENTAL OR CONSEQUENTIAL DAMAGES RESULTING FROM THE BREACH OF ANY WARRANTY, INCLUDING, BUT NOT LIMITED TO, LIABILITY FOR INCONVENIENCE, RENTAL OR PURCHASE OF REPLACEMENT EQUIPMENT, OR FOR LOSS OF PROFITS OR OTHER COMMERCIAL LOSS.
8. Some states do not allow limitations on how long an implied warranty lasts, so the above statement may not apply to you. Some states do not allow the exclusion or limitation of incidental or consequential damages, so the above limitation or exclusion may not apply to you.
9. This Warranty gives you specific legal rights, and you may have other rights which vary from state to state.
10. A Gravely product registration card is supplied with each Gravely Product. Please complete the card and return it to Gravely at the address listed on the card. The equipment registration card will be used by Gravely for:
 - a. Recording date of purchase.
 - b. Notification of owners in compliance with the Consumer Product Safety Act, should any notification be necessary.The return of such card is necessary for your warranty to be effective.
11. This Warranty is not subject to change or modification by anyone, including Gravely dealers and no Gravely dealer is authorized to make any representations or promises on Gravely's behalf.

 **GRAVELY**

One Gravely Lane, Clemmons, NC 27012